

We are IntechOpen, the world's leading publisher of Open Access books Built by scientists, for scientists

4,200

Open access books available

116,000

International authors and editors

125M

Downloads

Our authors are among the

154

Countries delivered to

TOP 1%

most cited scientists

12.2%

Contributors from top 500 universities



WEB OF SCIENCE™

Selection of our books indexed in the Book Citation Index
in Web of Science™ Core Collection (BKCI)

Interested in publishing with us?
Contact book.department@intechopen.com

Numbers displayed above are based on latest data collected.
For more information visit www.intechopen.com



Chapter

Mass Spectrometry as a Workhorse for Preclinical Drug Discovery: Special Emphasis on Drug Metabolism and Pharmacokinetics

Vijayabhaskar Veeravalli, Lakshmi Mohan Vamsi Madgula and Pratima Srivastava

Abstract

Mass spectrometry as an instrument is popular, given its sensitivity, selectivity, speed and robustness. In this chapter, we have briefly deliberated on various mass spec platforms, their hardware components and specific applications in preclinical drug discovery with a special emphasis on drug metabolism and pharmacokinetic assays. Basic principle of operation of mass spectrometer and various ionization techniques/mass analyzers was explicitly discussed. Compatibility of mass spectrometers with ultrafast LC and various throughput techniques, enabled evaluation of thousands of compounds with quick turnaround times. Faster generation of results corresponding to in vitro ADME and in vivo pharmacokinetic assays, aid medicinal chemists to refine their combinatorial synthetic chemistry efforts and expedite the lead optimization and identification phases of drug discovery. Mass spectrometer is a powerful tool for both qualitative and quantitative applications. While quantitative applications include measurement of absolute/relative concentrations, qualitative features assist in identification of molecular structures of metabolites and putative biotransformation pathways. Qualitative inputs are more precise and accurate, with the advent of high-resolution mass spectrometry technology. Although, mass spectrometry has many built-in advantages, it also suffers from matrix effects, as the samples analyzed are mostly of biological origin and are complex in nature. In this chapter, we have defined the nature of matrix effects and various approaches by which these matrix effects can be mitigated.

Keywords: mass spectrometer, mass analyzers, ionization sources, DMPK, ADME, LC-MS/MS, matrix effects

1. Introduction

Since its discovery 100 years ago by Sir J.J. Thompson for the quantitative measurement of the mass and charge of cathode rays, mass spectrometer eventually evolved as a reliable analytical platform aimed at the analysis of small and large molecules [1]. While hyphenation of mass spectrometry with gas chromatography achieved its early success, however, liquid chromatography could not due to indigent mass spec interfaces. This is given the inability of interfaces to handle

higher flow rates of liquid sample. Additionally, ionization techniques such as chemical and electron impact ionization did not suit for thermolabile and high molecular weight compounds [2, 3]. Advancement in ionization techniques such as fast atom bombardment that suited for analysis of large molecules, thermospray and particle beam ionization which were efficient for small molecules enabled the fruitful hyphenation of liquid chromatography with mass spectrometry [4–7]. Thermospray in general forms ammonium adducts, while particle beam generated electron impact spectra. Within a few years thermospray was succeeded by atmospheric pressure ionization techniques such as electrospray ionization (ESI), atmospheric pressure chemical ionization (APCI), atmospheric pressure photoionization (APPI) and atmospheric pressure matrix assisted laser desorption ionization (AP-MALDI). Mass spectrometer operates on the principle of ionization of analytes followed by their separation based on their mass-to-charge ratio [8]. Various mass spectrometer analyzers ranging from linear trap, ion trap, triple quadrupole, time of flight and orbitrap have specific applications for sample analysis in preclinical drug discovery and development.

Medicinal chemistry efforts in drug discovery is majorly focused on understanding the right combination of new chemical entity (NCE) properties that helps in cherry-picking the compounds with promising properties to progress from discovery to development phase. In the process of lead optimization, NCE's are subjected to a series of drug metabolism and pharmacokinetic assays to assess the druggable properties and mitigate late stage failures. Almost 40% of failures in development phase were due to poor pharmacokinetic properties of NCE's [9]. However, this percentage had gradually decreased to 10% as major pharmaceutical companies incorporated drug metabolism and pharmacokinetic screening (DMPK) in lead optimization phase of drug discovery. In this view, compounds must pass through a series of screens that scrutinize the problematic compounds until a small number have been selected for more rigorous testing in the development phase. Hence, lead optimization typically is an iterative process that uses the DMPK data to optimize the druggable properties of NCE's. Regardless of the screening panel, qualitative and quantitative analytical results to understand absorption, distribution, metabolism and excretion (ADME) properties were generated using liquid chromatography–tandem mass spectrometry (LC–MS/MS) [10–17]. In this chapter, we have briefly discussed on various atmospheric pressure ionization techniques/mass analyzers, and applications of mass spectrometer in drug discovery with special emphasis on drug metabolism and pharmacokinetic assays.

2. Atmospheric pressure ionization

Ionization in atmospheric ionization sources occur at atmospheric pressure and ions then gets transferred into the vacuum. As the liquid completely converts in to gas phase in the ionization source, those ionization techniques that use atmospheric pressure ionization are more convenient to hyphenate with liquid chromatography. These ionization techniques include electrospray ionization (ESI), atmospheric pressure chemical ionization (APCI), and atmospheric pressure photoionization (APPI) and are most widely used. Additionally, MALDI that also uses atmospheric pressure ionization is getting popular with its unique feature in performing mass spectrometry imaging (MSI) and analysis of large molecules [18]. Also, other ionization techniques such as desorption electrospray (DESI) or direct analysis in real time (DART) are becoming popular for the analysis of surface or solid samples [19, 20]. However, their applications in the field of drug metabolism and pharmacokinetics are very limited.

2.1 Electrospray ionization (ESI)

In ESI, analytes initially get charged with the assistance of electrical energy and charged ions transfer from solution to gaseous phase, before subjecting to mass spectrometric analysis. Ionic species in solution can be analyzed as such, whereas neutral compounds can be converted to ionic species and studied by ESI-MS. Electrospray ionization occurs in four stages: 1) charging of analytes in the capillary tube 2) formation of fine spray of charged droplets 3) solvent evaporation 4) columbic explosion/Rayleigh scattering of ions from the droplet (**Figure 1**). The liquid effluent moves from liquid chromatography to the mass spectrometer through a fused silica capillary maintained at voltage of 2.5–6.0 KV. In negative mode, to avoid discharge the range is lower (3–4 KV) than positive mode. ESI is a condensed phase ionization process and the ions have to be already present in solution. To generate ions, the pH has to be adjusted in such a way that ionizable groups are either protonated or deprotonated. In some cases, neutral molecules can be analyzed by the formation of adducts with ions such as ammonium, sodium, potassium, acetate or silver. Charged droplets undergo nebulization in the presence of nebulizer gas. After nebulization, charged droplets further reduce in size with the assistance of heat and breakdown in to minute droplets. Finally, as the droplets grow smaller and smaller, ions get released in to gaseous phase by a mechanism called rayleigh scattering/columbic explosion. The emitted ions are sampled by a sampling skimmer cone and are then accelerated into the mass analyzer for subsequent measurement of molecular mass and ion intensity [21–24]. An important characteristic of ESI-MS is it works as a concentration-dependent detector, which means MS response is directly proportional to concentration of analyte. Hence, irrespective of flow rate of mobile phase post column to the ionization source, response remains the same as long as the source-gas conditions are optimal for the flow rate. ESI technique is suitable for the analysis of polar to moderately polar molecules.

2.2 Atmospheric pressure chemical ionization (APCI)

In atmospheric pressure chemical ionization, unlike ESI, sample evaporation occurs first, followed by ionization in gas phase through corona discharge needle (**Figure 2**) [25]. The ionization principle is mostly similar to chemical ionization; however, it occurs at atmospheric pressure. APCI-MS can also be called as mass-sensitive detector, as the higher flow that goes in to ionization source, the higher will

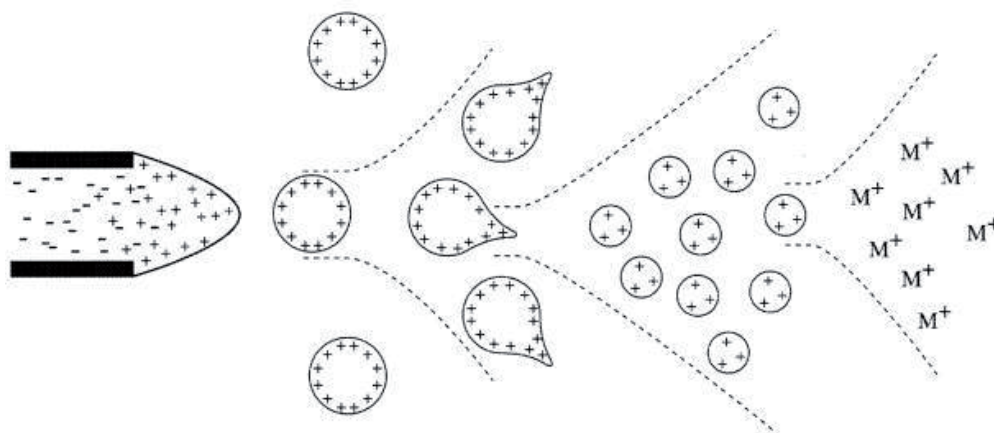

Figure 1.
Mechanism of electrospray ionization process.

be the peak response. One important requirement in APCI for optimal sensitivity is the sample has to be completely evaporated, before subjecting to ionization. First an aerosol of mobile phase is formed with the assistance of nebulizer gas. This aerosol is further subjected to heating at 200–550°C in a ceramic tube enabling complete evaporation. Even though higher temperatures are employed, the actual temperature felt by analyte molecules is way lesser due to a phenomenon called evaporative cooling effect/evaporation enthalpy. Next, analyte molecules in gas phases were bombarded with electrons formed from corona discharge needle [26, 27]. In positive mode primary ions such as N_2^+ are formed by electron impact. These ions further react with water in several steps by charge transfer to form H_3O^+ . Ionization of the analytes occurs then by proton transfer from H_3O^+ . In negative mode ions are formed either by: (i) resonance capture (AB to AB^-), (ii) dissociative capture (AB to B^-) or (iii) ion–molecule reaction (BH to B^-). One disadvantage with APCI when compared to ESI is, APCI is not suitable for thermolabile compounds as typical temperatures experienced by the analyte molecules are $\sim 150^\circ\text{C}$. However, in case of ESI, molecules encounter temperatures $\sim 40^\circ\text{C}$ in the process of evaporation.

2.3 Atmospheric pressure photo ionization (APPI)

APPI by design is similar to APCI, with only difference being the replacement of corona discharge needle with gas discharge krypton lamp (10.0 eV) that produces ultraviolet photons [28–30]. Evaporation of liquid phase happens in pneumatic nebulizer. While ionization potential for most of the analytes is less than 10 eV; mobile phase constituents such as water, acetonitrile and methanol has higher potential requirements. Presence of dopants such as toluene or acetone will help in enhancing the sensitivity of analyte ions. Dopant molecules absorb photon energy and eject an electron, resulting in the formation of radical cation. Ionization of analytes can happen by two processes: 1) Charge transfer between analyte and radical cations generated from dopant molecules. 2) Charge transfer between dopant molecules and mobile phase components and finally from mobile phase components to analytes (Figure 3). Similar to other atmospheric pressure ionization techniques, APPI is also suitable for negative mode of ionization. Sensitivity of APPI is flow rate dependent and better sensitivities have been reported at low flow rates. When compared to APCI, APPI offers lesser matrix effects and minimal source contamination. Success of APPI as an ionization technique was reported in the analysis of steroids and quinones [31–33].

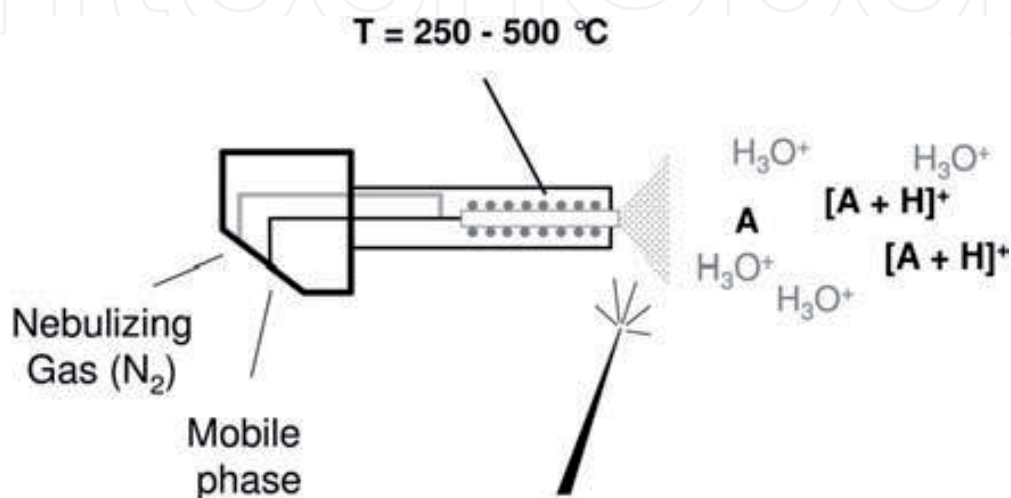

Figure 2.
Mechanism of atmospheric pressure chemical ionization process.

In a nut shell, ESI is useful for the analysis of moderately polar to highly polar analytes; APCI covers moderately polar to non-polar analytes, whereas APPI suits for non-polar to moderately polar analytes.

2.4 Matrix assisted laser desorption ionization (MALDI)

MALDI operates on principle of ionization of analytes dissolved in a matrix consisting of organic compound (sinapinic acid, α -cyano-4-hydroxycinnamic acid, 2,5-dihydroxybenzoic acid) and evaporated to dryness on a target plate [34]. Matrix crystallizes up on drying and the analyte dissolved with in it also gets co-crystal-lized. Firstly, laser beam hits the dried sample and ionize organic compound, which later ionize the analyte molecules. Laser beam causes both desorption and ioniza-tion of analytes. Nitrogen laser emitting at 337 nm and Nd: YAG laser emitting at 355 nm are the most widely used ones (**Figure 4**). MALDI is considered as a very

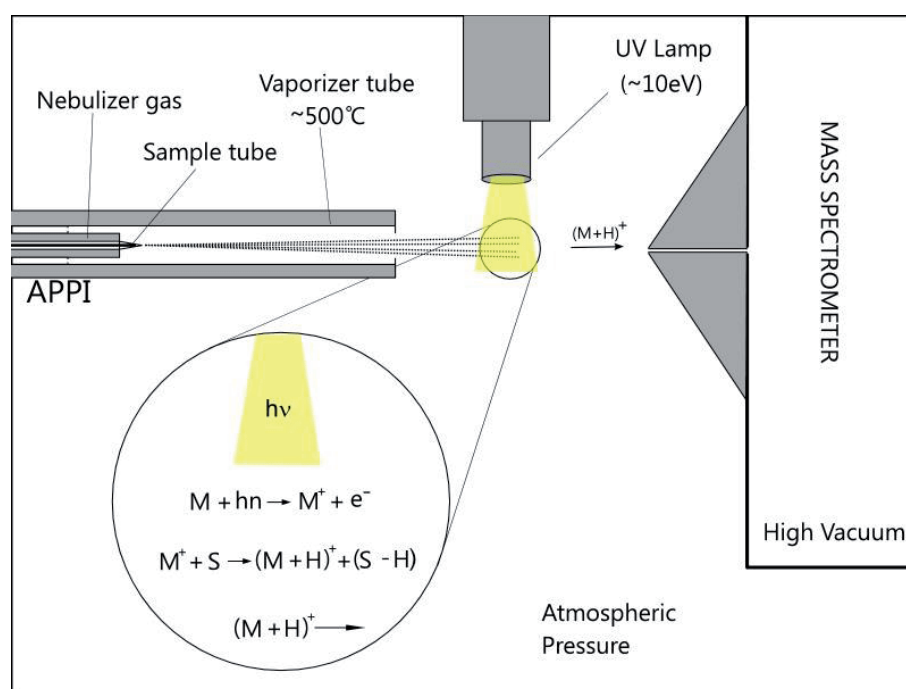

Figure 3.
Schematic representation of atmospheric pressure photo ionization process.

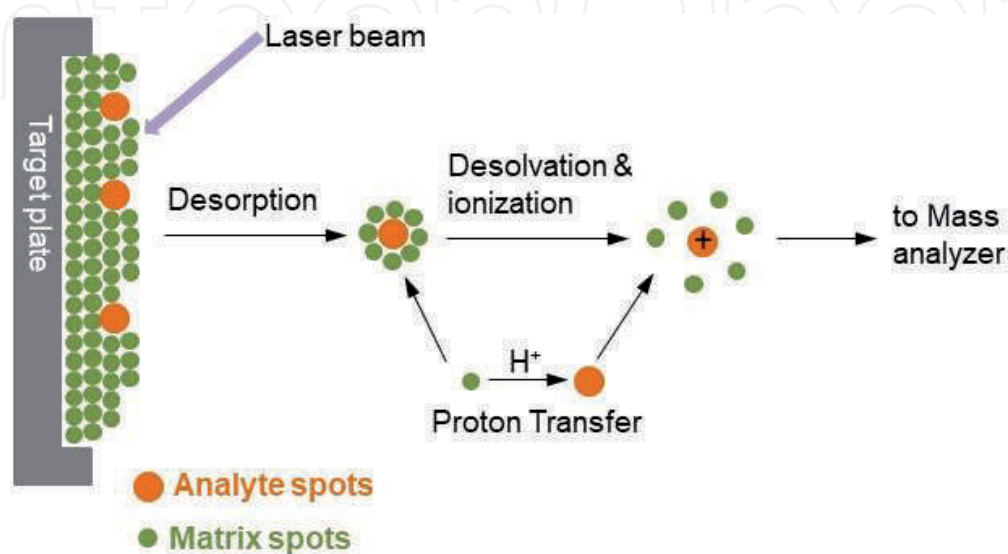

Figure 4.
Mechanism of matrix assisted laser desorption ionization process.

soft ionization technique that causes minimal fragmentation of the analyte ions and is also suitable for analysis of large molecules ranging from peptides to proteins, lipids and polymers [35–38]. It is also amenable to high throughput and target sample plates can be readily stored for future use. One major advantage of MALDI-MS is chromatographic separation of analytes is not required. However, due to lack of separation, matrix interferences impact the analytical results [39, 40]. Additionally, MALDI is not suitable for low molecular weight compounds. Also, MALDI needs TOF as an analyzer to cover high mass range in a linear mode, whereas ESI can be coupled with any mass analyzer. Recently, MALDI has been coupled to triple quadrupole and successfully used for the analysis of small molecules [41, 42].

3. Mass analyzers

3.1 Quadrupole analyzer

Quadrupole mass analyzer consists of four hyperbolic or circular rods positioned in parallel and are located diagonally at identical distances from each other. The rods are diagonally connected. Positive direct current (DC; U) is applied to one pair of rods and negative potential is applied to the other pair of rods. Apart from direct current, alternating radiofrequency (RF; $V \cos \omega t$) potential is also applied to these rods. The ion trajectory is affected in x and y directions by the total electric field composed by a quadrupolar alternating field and a constant field. Because there is only a two-dimensional quadrupole field the ions accelerated after ionization, maintain their velocity along the z axis.

The motion of ions in the quadrupole can be best described by Mathieu Equations [43]. The ions supposedly travel in a stable trajectory and only those ions that travel in stable trajectory reaches detector. Mass spectrum is obtained by ramping RF and DC voltages in a constant ratio. When DC voltage is set to zero and RF voltage is maintained, all ions pass through quadrupole. It is the DC voltage that helps in filtering out the ions of interest and generate mass spectrum (**Figure 5**). Hence, the quadrupoles that apply only RF voltages just act as ion guides or collision cell. Mass resolution for typical quadrupole analyzers falls in the range 0.6–0.8 da units, which is defined to be a unit resolution. However, current generation high resolution mass spectrometers offer to determine masses within 5–10 ppm error.

3.2 Triple quadrupole mass analyzer

Triple quadrupole mass analyzer consists of two RF/DC mass analyzers and two RF only mass analyzers. Q0 and Q2 (collision cell) were considered to be RF only quadrupoles, whereas Q1 and Q3 falls under RF/DC mass analyzers [44]. Hence, Q0 and Q2 acts as ion guides and Q1 and Q3 acts as mass filters. Q0 acts as an ion guide by focusing all the ions obtained from ionization source to Q1. Q1 even though a RF/DC mass analyzer, can also be operated in RF only quadrupole depending on the type of analysis. When it comes to qualitative analysis, Q1 acts as a RF only quadrupole, whereas in case of quantitative analysis it acts as RF/DC quadrupole. Similarly, Q3 also operates in both modes based on the analytical requirements. Q2 in addition being a RF only quadrupole, acts as a collision cell to fragment the ions and generate compound specific information, which enables the mass spec to be a more specific and selective detection system (**Figure 6**). Process of generation of fragment ions in the collision cell is termed as collision induced dissociation (CID), which happens with the assistance of neutral argon or nitrogen gas [45, 46].

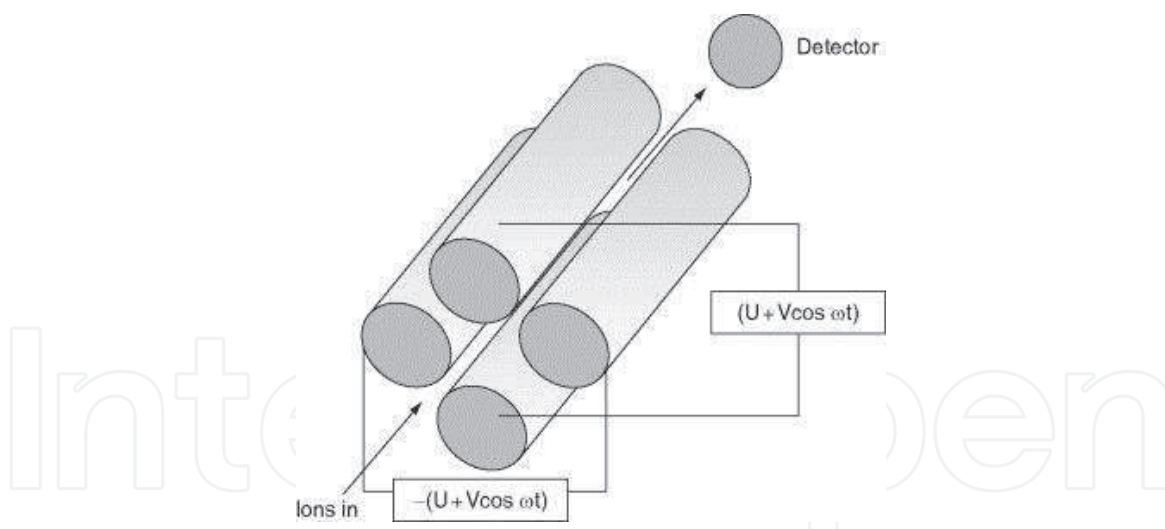

Figure 5.
Schematic diagram of operation of quadrupole mass analyzer.

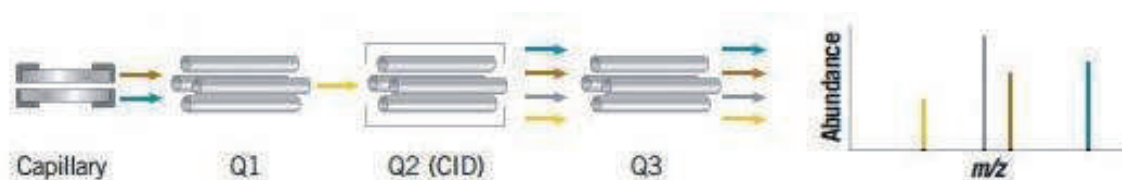

Figure 6.
Schematic diagram of triple quadrupole mass analyzer.

Based on the modes in which the mass analyzers are operated and the analytical requirements, they can be briefly classified as below:

While full scan modes are useful in understanding the total pool of masses present in the sample analyzed, product ion scan helps in obtaining structural information of a precursor ion. Precursor ion scan is suited to find structural homologs of a selected fragment ion. In multiple reaction monitoring mode (MRM), a selected parent ion (Q1 mass) is fragmented within the collision cell and selected fragment ion analyzed by the detector. Together this series of events forms a reaction where multiple ions are monitored, hence the term multiple reaction monitoring.

3.3 Linear ion trap mass analyzer

The quadrupole ion trap and the related quadrupole mass filter were invented by Paul and Steinwedel [47]. A quadrupole ion trap (QIT or 3D-IT) mass spectrometer operates with a three-dimensional quadrupole field. The QIT is formed by three electrodes: a ring electrode with a donut shape placed symmetrically between two end cap electrodes. QIT is a RF only quadrupole that acts a storage device and ions are focused to center of trap by collision with helium gas. Motion of ions in trap is regulated by axial and radial frequencies. The quadrupole ion trap can store only a limited number of ions before space charging occurs. To circumvent this effect, most instruments have an automatic gain control procedure (AGC). This procedure exactly determines the adequate fill time of the trap to maximize sensitivity and minimize resolution losses due to space charge. Ion motion can be modified either by exciting the radial or the axial frequencies by applying a small oscillating potential at the end cap electrodes during the RF ramp. Linear ion trap enables higher sensitivity than triple quadrupole mass spec analyzers in full scan mode, given the capability of ion accumulation before traveling to the detector (**Figure 7**).

Mode	Q0	Q1	Q2	Q3	Analysis type
Full scan mode (Q1 MS)	RF only	RF/DC	RF only	RF only	Qualitative
Full scan mode (Q3 MS)	RF only	RF only	RF only	RF/DC	Qualitative
Product ion scan (PI)	RF only	RF/DC	RF only	RF only	Qualitative
Precursor ion scan (PC)	RF only	RF only	RF only	RF/DC	Qualitative
Multiple reaction monitoring (MRM)	RF only	RF/DC	RF only	RF/DC	Quantitative

Table 1.
Modes of triple quadrupole operation and analytical requirements.

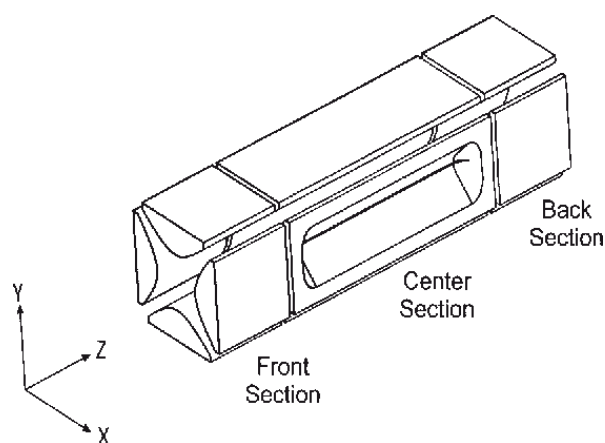

Figure 7.
Schematic diagram of linear ion trap mass analyzer.

There are more than a few important features which impact the time necessary to attain a mass spectrum (duty cycle): (i) injection time (0.5–500.0 ms), (ii) scan speed (5000–20,000 m/z units/s), (iii) separation of the parent ion and fragmentation in tandem MS or MS^n . Contrarily to the triple quadrupole, MS/MS is not performed in space but in time. Fragmentation happens with the assistance of helium as collision gas. Also, duty cycles for fragmentation (MS/MS) are much shorter in linear ion trap when compared to triple quadrupole mass analyzer. One major challenge in linear ion trap is to trap precursor ion and fragment in the same space. Often, due to this disadvantage, fragmentation spectra generated in linear ion trap differs from that of triple quadrupole CID. Also, number of MRM transitions that can be monitored in linear ion trap are quite less [4–8] when compared to QqQ mass analyzers (~100 MRM transitions can be monitored).

Due to the high sensitivity in MS^n mode, ion traps are particularly attractive for qualitative analysis in drug metabolism, metabolomics and proteomics studies. Similar sensitivities to QqQ mass analyzer can be achieved for quantitative analysis on linear ion trap, but at the price of precision and accuracy.

While linear ion traps mainly function on radial ejection, next generation mass analyzers called quadrupole linear ion trap use axial ejection. This led to discovery of hybrid triple quadrupole mass analyzers, where Q3 performs the function of both quadrupole and linear ion trap [48, 49]. Unlike linear ion trap that fragments precursor in time, these hybrid analyzers perform fragmentation in space. The

major advantage of this analyzer is that qualitative and quantitative analysis can be performed in the same LC–MS run.

3.4 Time of flight mass analyzer

Discovered in 1940's, time of flight mass analyzers achieved popularity after 1990's. Time of flight operates on principle of "time that ions need to cross in a field free tube of about 1 m length" [50, 51]. The motion of an ion is characterized by its kinetic energy $E_c = 0.5 m \times v^2$ (m = mass, v = speed). Therefore, the time ions fly through the tube is directly proportional to their m/z value. The velocity of the ions formed is generally low and they are accelerated by strong electric fields (2000–2030,000 V) in the direction of the detector. Low mass ions reach the detector more rapidly than high mass ions. Due to the short flight time (50–100 msec) and the good transmission, a spectrum can be generated within 100 ms over an almost unlimited mass range. Mass resolution of time of flight mass analyzer depends on the length of flight tube and reduced kinetic energy spread of the ions. Length of flight tube is directly proportional to mass resolution. Kinetic energy spread can be reduced by increasing time delay between ion formation and acceleration, also known as delayed pulse extraction. Also, positioning of electrostatic mirror in the drift region of ions increases the mass resolution (**Figure 8**).

Briefly, the ions with high energy penetrate deeper into the ion mirror region than those with the same m/z at a lower energy. Because of the different trajectories, all ions of the same m/z reach the detector at the same time. With the reflectron the flight path is increased without changing the physical size of the instrument. Commercial TOF instruments are available to operate in either linear mode or reflectron mode. Even though ESI can be coupled with TOF, but the combination of MALDI and TOF is most popular as both operate on the principle of pulsed technique. Coupling of ESI with TOF needs orthogonal acceleration to drive continuous beam of ions [52].

Time of flight instruments are designed to use for qualitative analysis with MALDI or atmospheric pressure ionization. MALDI hyphenated with time of flight analyzer enables the identification of large molecules such as proteins, peptides, lipids and polymers. MS/MS information can also be obtained by CID in drift tube with the assistance of nitrogen or argon as collision gas. However, as quadrupole

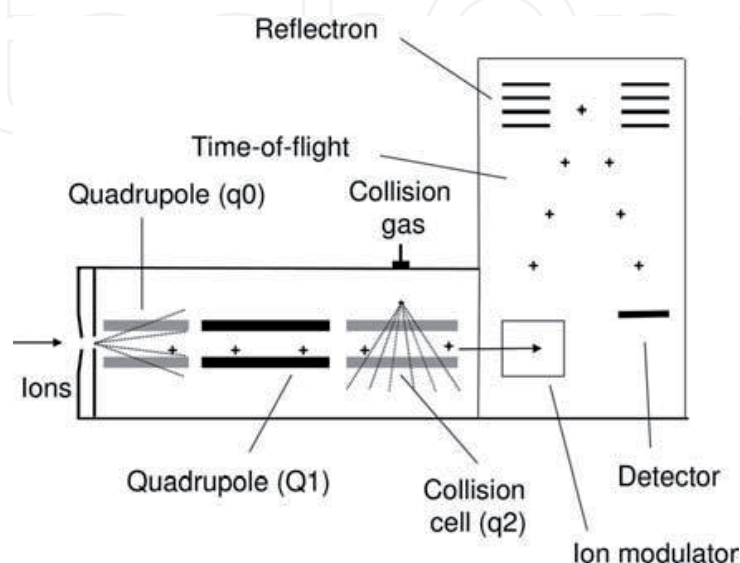

Figure 8.
Schematics representation of a quadrupole time of flight mass spectrometer.

technology is so successful for both qualitative and quantitative analysis, TOF analyzers are used as a hybrid platform with quadrupole analyzers. In these hybrid systems, TOF analyzer replaces Q3 of a triple quadrupole system. These hybrid systems are termed as QTOF mass spectrometers. QTOF systems offer high mass resolution ($\sim 40,000$) and sensitivity. Accurate mass measurements are especially useful in metabolite identification studies and peptide analysis [53]. Various other hybrid TOF platforms have been reported including, linear ion trap, quadrupole ion trap and TOF-TOF mass spectrometers [54–56].

3.5 Orbitrap mass analyzer

Orbitrap mass analyzer operates on principle of Fourier transform, where orbital trapping of ions around an electrode system is achieved with the assistance of electrical field [57]. The orbitrap is formed by a central spindle-like electrode surrounded by an electrode with a barrel-like shape to create an electrostatic potential. The m/z is a reciprocal proportionate to the frequency of the ions oscillating along the z -axis. Detection is performed by measuring the current image of the axial motion of the ions around the inner electrode. The mass spectrum is obtained after Fourier transformation of the image current. The orbitrap provides a mass resolving power exceeding 100,000 and a mass accuracy ~ 3 ppm. To be operational as a mass spectrometer the orbitrap requires external ion accumulation, cooling and fragmentation (**Figure 9**).

The first commercial instrument to utilize this capability, LTQ Orbitrap Classic, was introduced by Thermo Fisher Scientific in 2005, which later underwent many innovations with the addition of a collision cell after the C-trap in LTQ Orbitrap XL, addition of electron transfer dissociation (ETD) capabilities, followed by MALDI source operating at reduced pressure with high-end LTQ Orbitrap XL MALDI instrument, and finally a stacked ring rf ion guide (so called S-lens) brought about 10-fold higher transfer efficiency in the MS/MS mode.

Typically, the highest resolving powers available in TOF devices are several times lower than the resolution in Orbitrap, although recent multipass TOF devices

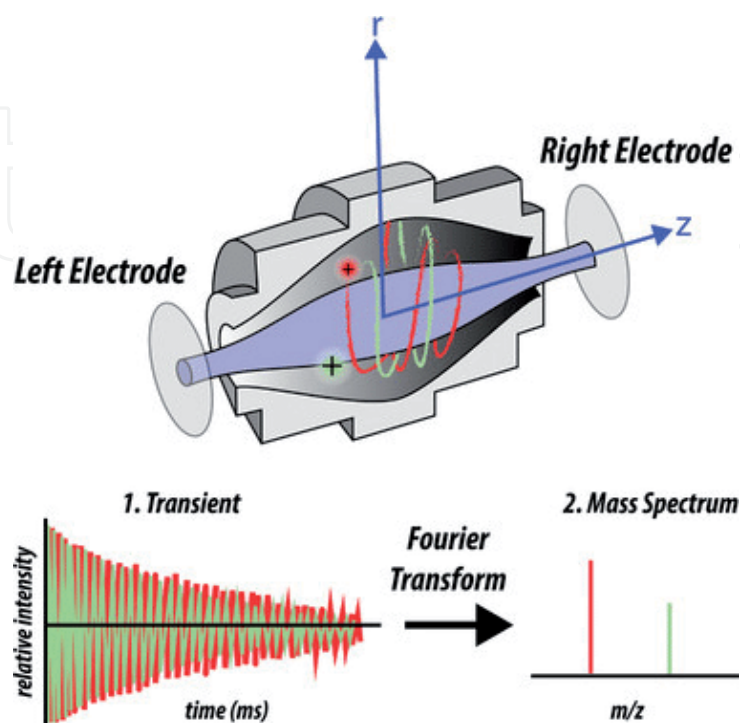

Figure 9. Schematic representation of operation of orbitrap mass analyzer.

are capable of ultrahigh resolution ($R \geq 100,000$ at m/z 400) [58, 59]. While TOF accompanies similar resolution in both MS and MS/MS modes, orbitrap suffers from low resolution in MS/MS mode. Orbitrap technology will endure to progress towards increased resolving power, acquisition speed, sensitivity and mass accuracy. These developments will indisputably open the arena for new applications as the Orbitrap instruments are getting more prevalent and exploring into new areas of research.

4. Applications in drug discovery

4.1 ADME studies

Drug discovery research was solely driven by chemists and pharmacologist in early 1990's, when very little is known about drug absorption, distribution, metabolism and elimination (ADME). However, it did not take much time before researchers realized the importance of optimizing ADME properties of NCE's for successfully driving drug discovery programs [60]. In this section, we highlighted importance of ADME in drug discovery and its relation to mass spectrometry.

Drug metabolism also known as xenobiotic biotransformation is the process by which lipophilic compounds gets eliminated from the body after getting converted to hydrophilic species that are easily filtered through kidney. While metabolism is desired in few cases where metabolites are the active species producing efficacy, there are metabolites that are toxic in nature. In such cases, where toxic by-products are produced, metabolism is not desired. Metabolism as a discipline drawn its first attention after the publication of RT Williams on Detoxification mechanisms [61].

Drug metabolism over the years with the aid of mass spectrometry technology has evolved in understanding the metabolic pathways of NCE's and also to identify the metabolites (both desired and undesired) [62–65]. Mass spectrometry was initially hyphenated with gas chromatography to understand the metabolic behavior of NCE's. Gas chromatography worked well for analyzing volatile compounds and its metabolites, however it did not suit for nonvolatile and thermolabile compounds. With the advent of liquid chromatography that can handle and separate components without subjecting to evaporation, it became prevalent as an analytical tool for understanding drug metabolism in drug discovery and development [66, 67].

As a part of understanding the metabolic properties, NCE's will be initially screened for metabolic stability in across species (human/rat/dog/mouse/monkey) and in various matrices including microsomes/S9 fractions/cytosol/hepatocytes, plasma, tissue homogenates, and buffer. If metabolism is not desired then compounds will be screened for their stability in relevant matrices and compounds with moderate to high stability (defined by half-life and intrinsic clearance) are further optimized for additional ADME properties. Various Phase 1 metabolic reactions including oxidation, demethylation, hydroxylation and phase 2 metabolic reactions covering glucuronidation, sulfation, methylation, amino acids conjugation and glutathione conjugation can be quantitatively and qualitatively studied using LC-MS/MS. Additionally, for compounds that are unstable, understanding the soft spots responsible for instability helps medicinal chemists to make relevant structural modifications in order to stabilize the unstable compounds. Understanding the soft spots precisely, needs the assistance of high-resolution mass spectrometry instruments such as TOF and Orbitrap. With the accurate mass information obtained from these mass spec's, identifying a metabolite structure will be spot on.

Similarly, other in vitro parameters such as permeability, protein binding, solubility, lipophilicity, CYP inhibition and CYP induction also play a key role in

drug disposition [15, 68, 69]. All of these assays have high sensitivity requirements and demand quantification of analytes within a few nanomolar range. For example, in case of permeability assessment, low permeable compounds such as atenolol permeate poorly from apical to basolateral side complicates the quantification of the apparent permeability values, if analyzed with low sensitive detectors. Likewise, fraction unbound values for highly protein compounds such as warfarin were such low that it demands highly sensitive detectors to accurately quantify such low levels. Needless to mention that all of the assays performed to optimize ADME properties of NCE's require highly sensitive detection systems. Hence, with its superior detection sensitivity, mass spectrometer has become an indispensable tool to understand the *in vitro* ADME properties of NCE's.

As discussed in the previous sections, even though there exist many ionization techniques, atmospheric pressure ionization (API) was more successful in drug metabolism studies, given its rapid, specific and sensitive methodologies for the identification of drugs and its metabolites. Mass spectrometer instruments types used in ADME studies vary from those that provide nominal mass information and accurate mass information. Nominal mass instruments such as triple quadrupoles are useful for quantitative applications, whereas accurate mass instruments including QTOF and Orbitrap are used for both quantitative and qualitative applications.

Of the atmospheric pressure ionization techniques available, ESI and APCI are the most commonly used. While APCI can accommodate high flow rates and produce high sensitivity, nevertheless analytes are subjected to higher temperatures in the evaporation process and hence as an ionization technique is not suitable for thermolabile (esp. glucuronides, N-oxides and sulfates) compounds. However, ESI is comparatively a soft ionization technique and could efficiently ionize these fragile compounds without degradation. As a whole, mass spectrometer exhibits both qualitative and quantitative applications in drug metabolism studies. However, in case of other ADME battery of assays as described above, mass spectrometer is used majorly for quantitative applications.

4.2 Metabolite identification

Metabolite identification (Met-ID) provides a variety of inputs in drug discovery and development which includes *in vitro* metabolite profiling in early stages of lead identification/optimization, followed by *in vitro/in vivo* correlation in late stage lead identification, characterization of putative metabolites, cross-species comparison to identify the right tox preclinical species, understanding drug–drug interactions, and identifying pharmacologically active or toxic metabolites and the mechanisms by which they are formed [70, 71].

Met-ID is quite challenging when it comes to a) identification of vast number of diverse metabolites, b) metabolites that are of low abundance, and c) high throughput analytical requirements to screen majority of early leads in preclinical drug discovery [72]. Even though there exist various platforms such as triple quadrupole, linear ion trap, and Qtrap to quantitatively/qualitatively identify metabolites, they turned obsolete due to nominal mass information they generate and are no longer valuable [73].

The term mass resolution is used to describe the mass resolving power according to the degree to which two analytes with close m/z values can be separated and identified. A practical and convenient way of evaluating the mass resolution of an instrument is the use of the full width at half maximum (FWHM) definition in which the $m/z/\Delta m/z$ ratio is calculated, where m/z is the mass-to-charge value of an ion peak and $\Delta m/z$ is the full width at half the maximal height of the peak. Nominal mass instruments generate resolution in low thousands (1000–4000),

which cannot separate isobaric ions with similar nominal m/z value. However, high resolution mass spectrometers provide resolution in the range of higher thousands (10000–100,000), that successfully identify and separate isobaric ions (**Figure 10**).

For a given nominal mass, there exists many possible molecular structures for an assigned biotransformation pathway. Hence, for an accurate molecular structure the metabolite has to be scaled up in larger quantities and measured using NMR spectroscopy. However, scaling up metabolites to “mg” quantities need tremendous efforts, resources and is not an economical approach. Later, with the discovery of high-resolution mass spectrometers such as TOF and Orbitrap, that provides accurate mass to the fourth decimal, enabled accurate prediction of molecular structures of metabolites [74–79].

In principle, as long as data can be measured accurately, high-resolution data is sufficient to demonstrate the presence or absence of defined species. Apart from high resolution masses, modern mass spectrometers also generate data with higher accuracy. The term mass accuracy is used to define how close the mass measured by the mass spectrometer is to the theoretical exact mass of an ion. Mass accuracy

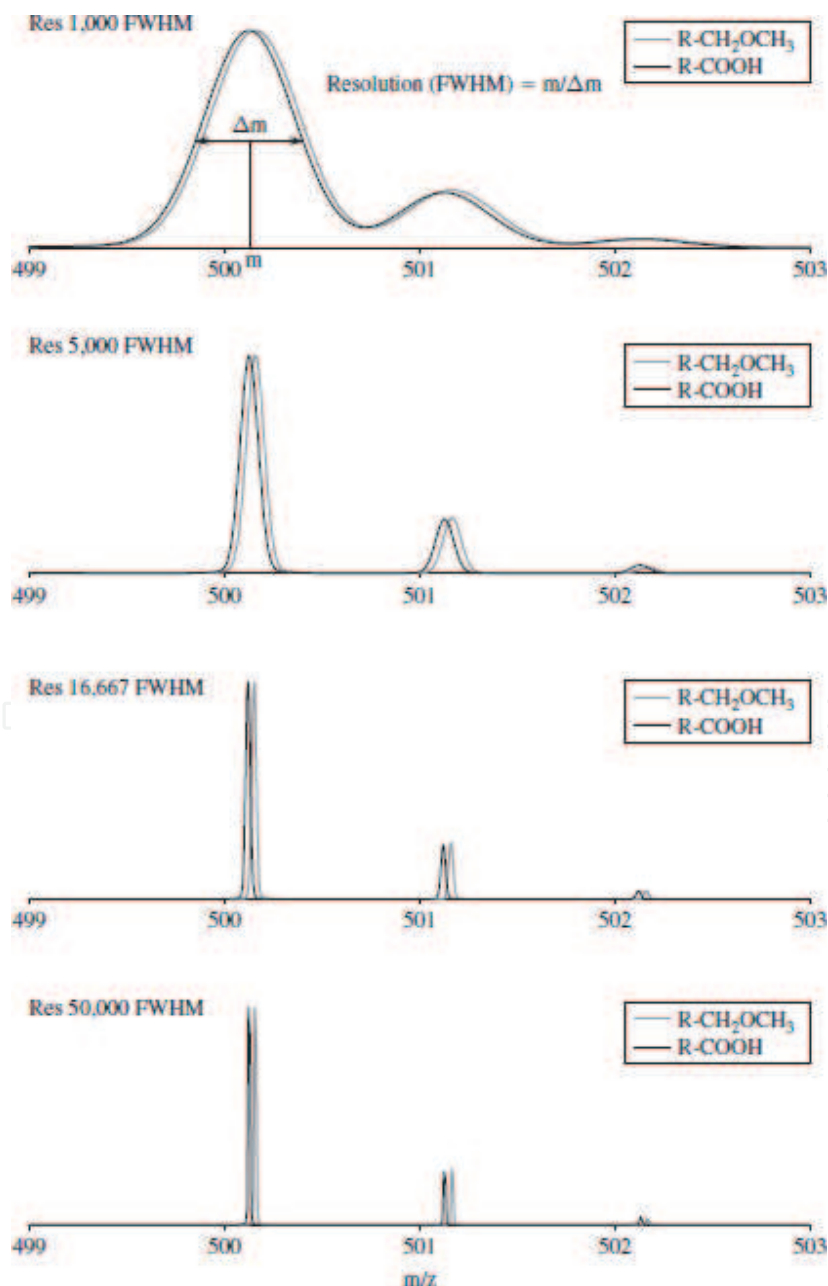

Figure 10. Increased resolution separating two closely arranged analytes with similar nominal m/z values.

is typically expressed as a relative mass error using the ratio of the difference between the experimental and theoretical m/z values over the theoretical m/z value of an ion.

Metabolite identification studies are typically performed in full scan mode (or) data dependent scan mode. In full scan mode, accurate mass information of parent ions is studied to understand the biotransformation pathways. However, to propose soft spots for metabolites, data dependent scans consisting of combination of full scan and product ion scans are performed. Metabolites in general can be considered as off springs to the parent molecular ions that carry similar fragments as that of parent ion (or) neutral loss fragments. In case of similar fragments to that of parent ion, these fragments can be considered unmodified and are similar to that of parent. Whereas, if the fragment ions are accompanied by a mass change for a given biotransformation pathway, then metabolite soft spot can be proposed with precision to that fragment ion (for example, in case of hydroxylation, neutral loss fragment in metabolite carries an additional mass of 16 amu) [80]. Additionally, apart from fragmentation scans accompanied with full scan, few other specific dependent scans consisting of neutral loss scan, and precursor ion scans are used to study various biotransformation pathways including glucuronidation, glutathione conjugation, sulfation (for example, glucuronidation is accompanied by a specific neutral loss of 176 da and glutathione conjugation by a neutral loss of 129 da in positive mode) [81, 82]. These specific scan functions are helpful in eliminating the background noise and identify the metabolites that exist even at lower abundance.

One major challenge in metabolite identification using LC-MS technology, is quantifying the relative abundance of metabolites. As mass spec quantitation is accompanied by many source/gas and compound dependent parameters that aid in the efficient ionization and detection, minor modifications in the metabolite structures alter the sensitivity by few orders of magnitude. Hence, quantitative results using mass spectrometer for the metabolites for which synthetic standards are not available, is not feasible. Additionally, it is difficult to synthesize each and every metabolite and determine their concentrations accurately. Alternatively, few researchers used LC-UV hyphenated with mass spectrometer to measure the relative abundance of metabolites. However, as majority of metabolites exist in low abundance, it becomes difficult to measure their relative abundance by UV spectroscopy. Also, UV is prone to differences in analytical sensitivities with minor modifications in structure. Hence, future mass spectrometers need to be designed to address these key concerns and facilitate evaluation of both quantitative and qualitative aspects of metabolites.

4.3 Pharmacokinetic analysis

Screening paradigm in drug discovery includes evaluation of compounds for their ADME properties by various in vitro assays. The datasets obtained from these assays help in rationalizing the synthetic chemistry efforts and make progress towards a pool of lead compounds that exhibit promising in vitro ADME properties. However, in vitro screening consists of unique assay platforms that can only answer a specific question of interest and can never cover all aspects of complex biological systems. Hence, it warrants the screening of selected lead compounds in preclinical species such as rats, mice, dog, pig and monkey, before progressing to clinic [83, 84]. Role of LC-MS/MS in performing bioanalysis of pharmacokinetic samples was well reported in the literature [85-88].

Design of pharmacokinetic studies varies from single route administration with few sampling points followed by multiple route administration with detailed time course evaluation. Samples of various natures ranging from blood, plasma,

serum are collected to analyze the systemic concentration levels. Additionally, to understand the tissue distribution of compounds, various tissues including liver, intestine, brain, spinal cord, heart, lungs, kidneys, skin and adipose tissue are also analyzed. Initially, lead compounds are dosed intravenously to understand the disposition parameters such as volume of distribution, clearance, half-life and mean residence time. Compounds that possess decent pharmacokinetic parameters in intravenous route are further evaluated in alternate (enteral and parenteral) routes to assess bioavailability and exposure parameters (C_{max} , T_{max} , AUC_{0-last}). To determine plasma concentrations as low as “ng” levels, sensitive analytical detectors are needed. HPLC-UV detector systems are proven robust for analyzing concentrations at higher “ μ g” level. However, as UV detection is not specific, it suffers from high background noise when biological samples are analyzed. High background noise in turn causes quantitation issues at the lower portion of calibration curve. On the other hand, LC-MS/MS detection system is considered to be highly specific and selective, as background noise can be eliminated by analyzing selected analytes of interest with desired m/z ratios. Also, mass spectrometric detection is considered highly sensitive than UV spectroscopic detection. Altogether, these advanced features, enabled LC-MS/MS to overcome the limitations of UV detection and is more frequently used in drug discovery and development for the bioanalysis of pharmacokinetic samples.

Of the various mass spectrometers available in the market, triple quadrupole LC-MS/MS systems have demonstrated tremendous success when it comes to quantitative applications. Monitoring specific reaction transitions that consist of parent and fragment ion, with associated source/gas and compound dependent parameters makes the mass spectrometer highly specific, selective and sensitive. Pharmacokinetic study samples are in general monitored for plasma concentrations over the time profile and hence triple quadrupole systems have achieved greater success. However, exploratory studies performed to understand metabolic pattern and biotransformation mechanisms of NCE's again need the assistance of linear ion traps and high-resolution mass spectrometer platforms (Orbitrap and TOF). As pharmacokinetic study samples are of biological origin and complex in nature, extracts obtained after sample preparation complicate the bioanalysis on LC-MS/MS. This phenomenon in broad terms is termed as Matrix effects. Causes of matrix effects and strategies to mitigate these effects are discussed in detail in the succeeding section.

Typically, pharmacokinetic studies are performed by administering a single test item in preclinical species. However, screening of single test item is labor intensive, not economical and demand higher turn-around times to generate pharmacokinetic data. Hence, researchers have come up with an alternate strategy, where a pool of compounds are administered in single dose, a technique well-known as cassette dosing or N-in-one dosing. The foundation for designing cassette dosing strategy comes from the ability of LC-MS/MS to analyze multiple test items without any chromatographic separation [89–92]. However, disadvantages with cassette dosing include altered pharmacokinetics due to drug–drug interaction potential, non-feasibility of pooling compounds with close molecular weights and compounds with differing physicochemical properties posing formulatability issues. Compounds with differing physicochemical properties comes with a challenge of formulating the selected pool of compounds in a single formulation vehicle. While issues with physicochemical properties and close molecular weights can be taken care of, drug–drug interaction appears to be of a major concern. One approach to minimize DDI's is by administering the compounds at minimal doses, collectively not exceeding the dose of single test item administration [93]. Also, dosing volumes can be kept as low as possible. Additionally, along with pool of unknown compounds, a quality control compound

with known pharmacokinetic parameters can be administered. Pharmacokinetic study results of unknown compounds can be considered acceptable, as long as quality control compounds fall within the set acceptance criteria. Compounds with less than 5 da difference in molecular weight are difficult to pool, when triple quadrupole systems are used for analyzing the pharmacokinetic samples. However, this challenge can be overcome by considering high resolution mass spectrometric analysis. Typical pharmacokinetic parameters studied from intravenous administration include half-life ($t_{1/2}$), clearance (Cl), volume of distribution (V_z), mean residence time (MRT), area under the curve (AUC_{0-last} ; AUC_{0-inf}), whereas parameters such as C_{max} , T_{max} and area under the curve are studied in other routes of administration. When compounds are dosed in multiple routes, along with intravenous route of administration, absolute bioavailability values are calculated.

Current fast LC-MS/MS instruments enable analysis of mixture of analytes with minimal separation, shorter run times and also feasible for hyphenation with ultra-fast liquid chromatography systems. Additionally, latest LC-MS/MS systems are capable of analyzing thousands of samples every week due to higher loading capacity of samples in autosampler, shorter run times and introduction of 96/384 well plate formats.

Test samples are analyzed against a calibration curve and a set of quality control samples. Calibration curve consists of 8–10 known standards and quality controls span the calibration curve at a minimum of 3 levels. Typical accuracy limits for qualifying the calibration and quality control samples is set as $\pm 20\%$. Typical turn-around times for execution of pharmacokinetic studies right from dosing initiation to generation of pharmacokinetic parameters spans 1–2 weeks. Importance of high throughput bioanalysis and its role in drug discovery is discussed in detail in the section below.

4.4 High throughput bioanalysis

With the combinatorial chemistry efforts leading to synthesis of hundreds of compounds in early phases of drug discovery, there is a constant need for analytical platforms that can quickly churn out data and help in accelerating the discovery process. LC-MS/MS with proven track record as a reliable analytical platform had undergone evolutionary changes to support high throughput demands of drug discovery [60, 70, 87, 94–96]. These strategies include advancements in chromatographic columns, where lower dimensions and microbore HPLC columns cut short run time to one minute per sample. Quick sample run times help in analyzing higher number of samples within the given stipulated time [97]. Faster gradient methods with LC pumps that can handle higher pressure also enable analysis with shorter run times [98]. With the invention of monolithic HPLC columns that can be operated at high flow rates in the order of 5–6 mL/min, analytical run times were significantly reduced [99–101]. One disadvantage of these columns is that the high flow rates translate in to higher usage of mobile phase, making it an expensive alternative.

Another approach for increasing sample throughput is by the use of parallel HPLC columns, where the effluent from two HPLC systems could be combined and assayed by using the MRM/SRM capabilities of the MS/MS system [102, 103]. One more approach in enhancing the throughput is through staggered analysis approach. Here, multiple HPLC columns are used, but the injection time is staggered such that the “analytical window” can be selected sequentially in order to maximize the use of the MS/MS system and increase sample throughput [104].

On the other hand, throughput can also be increased by pooling of samples, provided the sensitivity is not seriously compromised. When these samples are

analyzed on triple quadrupole systems, care must be taken to have molecular weight differences by at least 5 da. Typically, 4–5 analytes can be pooled and analyzed. Only challenge with pooling/cassette strategy (even with high resolution mass spectrometers) is its non-suitability for isomeric compounds. With advancements in instrumentation technology, modern LC autosamplers are designed to accommodate higher sample load. There are autosamplers that can accommodate as high as twelve 96 well plates. Higher loading capacity of autosamplers enable unattended analysis of large number of samples (**Figure 11**).

When it comes to sample preparation, robotic platforms can be used to screen larger pool of compounds across various in vitro assays. However, this strategy can also be used for processing of in vivo samples, provided if the sample cohort is higher. In general, automated robotic sample preparation platforms are quite often used for screening of compounds in in vitro assays. These robotic platforms help in decreasing the manpower involved and time taken for performing the assays. However, main disadvantage with robotic platforms is the need for preparation of larger volumes of reagents and the cost factor involved. Hence, it is not recommended to use these platforms unless there exists a larger library of compounds.

4.5 Matrix effects

With the sample nature being biological in origin, supernatants obtained after sample preparation consists of many endogenous components that compete with the analyte of interest and result in either suppression/enhancement of ionization. This process of alteration of the ionization of analytes is termed as matrix effects. The “matrix” refers to all components in the sample other than analyte(s) of interest. Matrix effects are defined as “interference from matrix components that are



Figure 11.
Pictorial representation of LC–MS/MS system with higher loading capacity of autosampler.

unrelated to the analyte” [105, 106]. The process of ion suppression/enhancement is in general referred as matrix effect and is main subject of various published reviews [107–112]. Matrix effects result in significant deviation in precision and accuracy of results which in turn debate the reliability of pharmacokinetic parameters of NCE's generated. Matrix effect alters the sensitivity, reproducibility and challenges the reliability of analytical techniques. Although matrix effects occur as a result of various exogenous and endogenous components, one major area of concern is formulation excipients (an exogenous component) used in the preparation of formulations. Dosing vehicles are generally used at high concentrations to solubilize test articles of highly lipophilic nature [113–115]. This in turn can be instrumental in causing matrix effects, thereby questioning the reliability of preclinical PK parameters. This phenomenon has been reported by us in the past for various excipients such as PEG 400 [110, 116, 117], Cremophor EL [111, 118] and Solutol HS15 [112, 119].

Several mechanisms have been proposed to explain matrix effects, but the exact process remains uncertain [120, 121]. Various mechanisms by which matrix components cause ion suppression are as follows:

- Charge competition between analyte and matrix components [122, 123].
- Change in droplet surface tension leading to formation of large droplets and insufficient desolvation [121, 124].
- Preferential ion evaporation due to matrix components gathering at droplet surface.
- Change in mass of analyte ion due to ion pairing and adduct formation
- Co-precipitation with non-volatile matrix components [125].
- Gas phase deprotonation.

Reduction of matrix effects can be achieved through various strategies including decreasing the level of matrix components, improving chromatographic separation of interfering materials from the analyte, various sample preparation strategies, lower injection volumes, and even by simple dilution of samples to reduce the overall concentrations of both analyte and co-extracted materials [126, 127]. Switching ionization sources will also help in mitigating the matrix effects [112, 116, 118, 119]. Matrix effects occurring in the early time point samples can be monitored, using another aliquot of the early time point samples analyzed at a higher dilution [128].

5. Conclusion

Over the past few decades, technological advancements in mass spectrometer enabled it to surpass other detection platforms and evolve as an indispensable analytical tool to support the bioanalytical needs of drug discovery and development. Current generation mass spectrometers could efficiently handle both qualitative and quantitative aspects of bioanalysis. Additionally, the likelihood of hyphenation of mass spectrometers with ultrafast liquid chromatography systems, extended its applications to high throughput bioanalysis. Even though significant achievements were made in the past, instruments will continue to get more and more sensitive and become better acquiescent to automation.

IntechOpen

Author details

Vijayabhaskar Veeravalli^{1*}, Lakshmi Mohan Vamsi Madgula¹
and Pratima Srivastava²

1 Syngene International Limited, Biocon Park, SEZ, Bangalore India

2 GVK BIO Pvt Ltd, Hyderabad, Telangana, India

*Address all correspondence to: vveerav1@jhmi.edu

IntechOpen

© 2019 The Author(s). Licensee IntechOpen. This chapter is distributed under the terms of the Creative Commons Attribution License (<http://creativecommons.org/licenses/by/3.0>), which permits unrestricted use, distribution, and reproduction in any medium, provided the original work is properly cited. 

References

- [1] Thomson JJ. Rays of positive electricity and their application to chemical analyses. Proceedings of the Royal Society. 1913;**89**:1-20
- [2] Gohlke RS. Time-of-flight mass spectrometry and gas-liquid partition chromatography. Analytical Chemistry. 1959;**31**:535-541
- [3] Arpino P, Baldwin MA, McLafferty FW. Liquid chromatography-mass spectrometry. II. Continuous monitoring. Biomedical Mass Spectrometry. 1974;**1**:80-82
- [4] Ito Y, Takeuchi T, Ishii D, Goto M. Direct coupling of micro high performance liquid chromatography with fast atom bombardment mass spectrometry. Journal of Chromatography. 1985;**346**:161-166
- [5] Caprioli RM, Fan T, Cottrell JS. A continuous-flow sample probe for fast atom bombardment mass spectrometry. Analytical Chemistry. 1986;**58**:2949-2954
- [6] Blakley CR, Vestal ML. Thermospray interface for liquid chromatography-mass spectrometry. Analytical Chemistry. 1983;**55**:750-754
- [7] Willoughby RC, Browner RF. Monodisperse aerosol generation interface for combining liquid chromatography with mass spectroscopy. Analytical Chemistry. 1984;**56**:2626-2631
- [8] Ho CS, Lam CW, Chan MH, Cheung RC, Law LK, Lit LC, et al. Electrospray ionisation mass spectrometry: Principles and clinical applications. Clinical Biochemist Reviews. 2003;**24**(1):3-12
- [9] Frank R, Hargreaves R. Clinical biomarkers in drug discovery and development. Nature Reviews. Drug Discovery. 2003;**2**(7):566-580
- [10] Lee MS. Integrated Strategies for Drug Discovery Using Mass Spectrometry. Vol. 550. Hoboken: John Wiley & Sons; 2005
- [11] Korfmacher W. Using Mass Spectrometry for Drug Metabolism Studies. Vol. 370. Boca Raton: CRC Press; 2005
- [12] Korfmacher WA. Lead optimization strategies as part of a drug metabolism environment. Current Opinion in Drug Discovery & Development. 2003;**6**(4):481-485
- [13] Korfmacher WA. Principles and applications of LC-MS in new drug discovery. Drug Discovery Today. 2005;**10**(20):1357-1367
- [14] Roberts SA. High-throughput screening approaches for investigating drug metabolism and pharmacokinetics. Xenobiotica. 2001;**31**(8-9):557-589
- [15] Eddershaw PJ, Beresford AP, Bayliss MK. ADME/PK as part of a rational approach to drug discovery. Drug Discovery Today. 2000;**5**(9):409-414
- [16] Kumar GN, Surapaneni S. Role of drug metabolism in drug discovery and development. Medicinal Research Reviews. 2001;**21**(5):397-411
- [17] Riley RJ, Martin IJ, Cooper AE. The influence of DMPK as an integrated partner in modern drug discovery. Current Drug Metabolism. 2002;**3**(5):527-550
- [18] Beine B, Diehl HC, Meyer HE, Henkel C. Tissue MALDI mass spectrometry imaging (MALDI MSI) of peptides. Methods in Molecular Biology. 2016;**1394**:129-150

- [19] Takats Z, Wiseman JM, Gologan B, Cooks RG. Mass spectrometry sampling under ambient conditions with desorption electrospray ionization. *Science*. 2004;**306**(5695):471-473
- [20] Cody RB, Laramée JA, Durst HD. Versatile new ion source for the analysis of materials in open air under ambient conditions. *Analytical Chemistry*. 2005;**77**(8):2297-2302
- [21] Liigand P, Kaupmees K, Haav K, Liigand J, Leito I, Girod M, et al. Think negative: Finding the best electrospray ionization/MS mode for your Analyte. *Analytical Chemistry*. 2017;**89**(11):5665-5668
- [22] Lubin A, Bajic S, Cabooter D, Augustijns P, Cuyckens F. Atmospheric pressure ionization using a high voltage target compared to electrospray ionization. *Journal of the American Society for Mass Spectrometry*. 2017;**28**(2):286-293
- [23] Wilm M. Principles of electrospray ionization. *Molecular & Cellular Proteomics*. 2011;**10**(7):M111.009407
- [24] Pozniak BP, Cole RB. Perspective on electrospray ionization and its relation to electrochemistry. *Journal of the American Society for Mass Spectrometry*. 2015;**26**(3):369-385
- [25] Carroll DI, Dzidic I, Stillwell RN, Haegele KD, Horning EC. Atmospheric pressure ionization mass spectrometry. Corona discharge ion source for use in a liquid chromatograph-mass spectrometer computer analytical system. *Analytical Chemistry*. 1975;**47**:2369-2372
- [26] Beccaria M, Inferrera V, Rigano F, Gorynski K, Purcaro G, Pawliszyn J, et al. Highly informative multiclass profiling of lipids by ultra-high performance liquid chromatography - low resolution (quadrupole) mass spectrometry by using electrospray ionization and atmospheric pressure chemical ionization interfaces. *Journal of Chromatography. A*. 2017;**1509**:69-82
- [27] Galani JHY, Houbraken M, Van Hulle M, Spanoghe P. Comparison of electrospray and UniSpray, a novel atmospheric pressure ionization interface, for LC-MS/MS analysis of 81 pesticide residues in food and water matrices. *Analytical and Bioanalytical Chemistry*. 2019;**411**:5099-5113
- [28] Robb DB, Covey TR, Bruins AP. Atmospheric pressure photoionisation: An ionization method for liquid chromatography-mass spectrometry. *Analytical Chemistry*. 2000;**72**(15):3653-3659
- [29] Raffaelli A, Saba A. Atmospheric pressure photoionization mass spectrometry. *Mass Spectrometry Reviews*. 2003;**22**(5):318-331
- [30] Bos SJ, van Leeuwen SM, Karst U. From fundamentals to applications: Recent developments in atmospheric pressure photoionization mass spectrometry. *Analytical and Bioanalytical Chemistry*. 2006;**384**(1):85-99
- [31] Grun CH, Besseau S. Normal-phase liquid chromatography-atmospheric-pressure photoionization-mass spectrometry analysis of cholesterol and phytosterol oxidation products. *Journal of Chromatography. A*. 2016;**1439**:74-81
- [32] Kauppila TJ, Syage JA, Benter T. Recent developments in atmospheric pressure photoionization-mass spectrometry. *Mass Spectrometry Reviews*. 2017;**36**(3):423-449
- [33] Vaikkinen A, Kauppila TJ, Kostianen R. Charge exchange reaction in dopant-assisted atmospheric pressure chemical ionization and atmospheric pressure photoionization. *Journal*

of the American Society for Mass Spectrometry. 2016;**27**(8):1291-1300

[34] Karas M, Hillenkamp F. Laser desorption ionization of proteins with molecular masses exceeding 10,000 daltons. *Analytical Chemistry*. 1988;**60**(20):2299-2301

[35] Rappsilber J, Moniatte M, Nielsen ML, Podtelejnikov AV, Mann M. Experiences and perspectives of MALDI MS and MS/MS in proteomic research. *International Journal of Mass Spectrometry*. 2003;**226**(1):223-237

[36] Nielen MWF. Maldi time-of-flight mass spectrometry of synthetic polymers. *Mass Spectrometry Reviews*. 1999;**18**(5):309-344

[37] Gut IG. DNA analysis by MALDITOF mass spectrometry. *Human Mutation*. 2004;**23**:437-441

[38] Schiller J, Suss R, Arnhold J, Fuchs B, Lessig J, Muller M, et al. Matrixassisted laser desorption and ionization time-of-flight (MALDITOF) mass spectrometry in lipid and phospholipid research. *Progress in Lipid Research*. 2004;**43**:449-488

[39] McCombie G, Knochenmuss R. Small-molecule MALDI using the matrix suppression effect to reduce or eliminate matrix background interferences. *Analytical Chemistry*. 2004;**76**(17):4990-4997

[40] Donegan M, Tomlinson AJ, Nair H, Juhasz P. Controlling matrix suppression for matrix-assisted laser desorption/ionization analysis of small molecules. *Rapid Commun Mass Sp*. 2004;**18**(17):1885-1888

[41] Poetzsch M, Steuer AE, Hysek CM, Liechti ME, Kraemer T. Development of a high-speed MALDI-triple quadrupole mass spectrometric method for the determination of 3,4-methylenedioxymethamphetamine

(MDMA) in oral fluid. *Drug Testing and Analysis*. 2016;**8**(2):235-240

[42] Gobey J, Cole M, Janiszewski J, Covey T, Chau T, Kovarik P, et al. Characterization and performance of MALDI on a triple quadrupole mass spectrometer for analysis and quantification of small molecules. *Analytical Chemistry*. 2005;**77**(17):5643-5654

[43] March RE, Todd JFJ. *Quadrupole Ion Trap Mass Spectrometry*. 2nd ed. Vol. 165. Hoboken, New Jersey, USA: Wiley-Interscience; 2005. p. 346

[44] Haag AM. Mass analyzers and mass spectrometers. *Adv. Exp. Med. Biol*. 2016;**919**:157-169

[45] de Hoffmann E. Tandem mass spectrometry: A primer. *Journal of Mass Spectrometry*. 1996;**31**:129-137

[46] Schwartz JC, Wade AP, Enke CG, Cooks RG. Systematic delineation of scan modes in multidimensional mass spectrometry. *Analytical Chemistry*. 1990;**62**(17):1809-1818

[47] Paul W, Steinwedel H. A new mass spectrometer without magnetic field. *Zeitschrift für Naturforschung*. 1953;**8a**:448-450

[48] Hager JW. A new linear ion trap mass spectrometer. *Rapid Communications in Mass Spectrometry*. 2002;**16**:512-526

[49] Hopfgartner G, Zell M. Q trap MS: A new tool for metabolite identification. In: *Using Mass Spectrometry for Drug Metabolism Studies*. Boca Raton, Florida, USA: CRC Press; 2004

[50] Mamyrin BA. Time-of-flight mass spectrometry (concepts, achievements, and prospects). *International Journal of Mass Spectrometry*. 2001;**206**:251-266

[51] Uphoff A, Grottemeyer J. Tutorial: The secrets of time-of flight mass

- spectrometry revealed. *European Journal of Mass Spectrometry*. 2003;**9**(3):151-164
- [52] Guilhaus M, Selby D, Mlynski V. Orthogonal acceleration time-of-flight mass spectrometry. *Mass Spectrometry Reviews*. 2000;**19**(2):65-107
- [53] Hopfgartner G, Chernushevich IV, Covey T, Plomley JB, Bonner R. Exact mass measurement of product ions for the structural elucidation of drug metabolites with a tandem quadrupole orthogonal-acceleration time-of-flight mass spectrometer. *Journal of the American Society for Mass Spectrometry*. 1999;**10**:1305-1314
- [54] Martin RL, Brancia FL. Analysis of high mass peptides using a novel matrix-assisted laser desorption/ionisation quadrupole ion trap time-of-flight mass spectrometer. *Rapid Communications in Mass Spectrometry*. 2003;**17**:1358-1365
- [55] Vestal ML, Campbell JM. Tandem time-of-flight mass spectrometry. *Methods in Enzymology*. 2005;**402**:79-108
- [56] Suckau D, Resemann A, Schuerenberg M, Hufnagel P, Franzen J, Holle A. A novel MALDI LIFT-TOF/TOF mass spectrometer for proteomics. *Analytical and Bioanalytical Chemistry*. 2003;**376**(7):952-965
- [57] Makarov A. Electrostatic axially harmonic orbital trapping: A high performance technique of mass analysis. *Analytical Chemistry*. 2000;**72**:1156-1162
- [58] Verentchikov AN, Yavor M, Hasin YI, Gavrik MA. Multireflection planar time-of-flight mass analyzer. I: An analyzer for a parallel tandem spectrometer. *Technical Physics*. 2005;**50**(1):73-81
- [59] Klitzke CF, Corilo YE, Siek K, Binkley J, Patrick J, Eberlin MN. Petroleomics by ultrahigh-resolution time-of-flight mass spectrometry. *Energy & Fuels*. 2012;**26**:5787-5794
- [60] Korfmacher W. Bioanalytical assays in a drug discovery environment. In: *Using Mass Spectrometry for Drug Metabolism Studies*. Boca Raton: CRC Press; 2005. pp. 1-34
- [61] Williams RT. *Deoxygenation Mechanisms: The Metabolism and Detoxication of Drugs, Toxic Substances and Other Organic Compounds*. Boca Raton, Florida, USA: Chapman and Hall; 1959
- [62] Korfmacher WA, Cox KA, Bryant MS, Veals J, Ng K. HPLC-API/MS/MS: A powerful tool for integrating drug metabolism into the drug discovery process. *Drug Discovery Today*. 1997;**2**:532-537
- [63] Yengi LG, Leung L, Kao J. The evolving role of drug metabolism in drug discovery and development. *Pharmaceutical Research*. 2007;**24**(5):842-858
- [64] Chiu SH, Thompson KA, Vincent SH, Alvaro RF, Huskey SW, Stearns RA, et al. The role of drug metabolism in drug discovery: A case study in the selection of an oxytocin receptor antagonist for development. *Toxicologic Pathology*. 1995;**23**(2):124-130
- [65] Oliveira EJ, Watson DG. Liquid chromatography-mass spectrometry in the study of the metabolism of drugs and other xenobiotics. *Biomedical Chromatography*. 2000;**14**:351-372
- [66] Olah TV. The development and implementation of bioanalytical methods using LC-MS to support ADME studies in early drug discovery and candidate selection. In: *Ernst Schering Research Foundation Workshop*. Berlin, Heidelberg: Springer; 2002. pp. 155-183
- [67] Lim CK, Lord G. Current developments in LC-MS for

pharmaceutical analysis. *Biological & Pharmaceutical Bulletin*. 2002;25(5):547-557

[68] Jenkins KM, Angeles R, Quintos MT, Xu R, Kassel DB, Rourick RA. Automated high throughput ADME assays for metabolic stability and cytochrome P450 inhibition profiling of combinatorial libraries. *Journal of Pharmaceutical and Biomedical Analysis*. 2004;34(5):989-1004

[69] Thompson TN. Early ADME in support of drug discovery: The role of metabolic stability studies. *Current Drug Metabolism*. 2000;1(3):215-241

[70] Hopfgartner G, Husser C, Zell M. High-throughput quantification of drugs and their metabolites in biosamples by LC-MS/MS and CEMS/MS: Possibilities and limitations. *Therapeutic Drug Monitoring*. 2002;24:134-143

[71] Cox K. Special requirements for metabolite characterization. In: *Using Mass Spectrometry for Drug Metabolism Studies*. Boca Raton: CRC Press; 2005. pp. 229-252

[72] Clarke NJ, Rindgen D, Korfmacher WA, Cox KA. Systematic LC/MS metabolite identification in drug discovery. *Analytical Chemistry*. 2001;73(15):430A-439A

[73] Hopfgartner G, Husser C, Zell M. Rapid screening and characterization of drug metabolites using a new quadrupole-linear ion trap mass spectrometer. *Journal of Mass Spectrometry*. 2003;38:138-150

[74] Leclercq L, Delatour C, Hoes I, Brunelle F, Labrique X. Use of a five-channel multiplexed electrospray quadrupole time-of-flight hybrid mass spectrometer for metabolite identification. *Rapid Communications in Mass Spectrometry*. 2005;19:1611-1618

[75] Bateman KP, Kellmann M, Muenster H, Papp R, Taylor L. Quantitative-qualitative data acquisition using a benchtop Orbitrap mass spectrometer. *Journal of the American Society for Mass Spectrometry*. 2009;8:1441-1450

[76] Chernushevich IV, Loboda AV, Thomson BA. An introduction to quadrupole-time-of flight mass spectrometry. *Journal of Mass Spectrometry*. 2001;36:849-865

[77] Hu Q, Noll RJ, Li H, Makarov A, Hardman M, Cooks RG. The Orbitrap: A new mass spectrometer. *Journal of Mass Spectrometry*. 2005;40:430-443

[78] Lim HK, Chen J, Sensenhauser C, Cook K, Subrahmanyam V. Metabolite identification by data-dependent accurate mass spectrometric analysis at resolving power of 60,000 in external calibration mode using an LTQ/Orbitrap. *Rapid Communications in Mass Spectrometry*. 2007;21:1821-1832

[79] Makarov A, Denisov E, Kholomeev A, Balschun W, Lange O, Strupat K, et al. Performance evaluation of a hybrid linear ion trap/orbitrap mass spectrometer. *Analytical Chemistry*. 2006;78(7):2113-2120

[80] Fernandez-Metzler CL, Owens KG, Baillie TA, King RC. Rapid liquid chromatography with tandem mass spectrometry-based screening procedures for studies on the biotransformation of drug candidates. *Drug Metabolism and Disposition*. 1999;27(1):32-40

[81] Mahajan MK, Evans CA. Dual negative precursor ion scan approach for rapid detection of glutathione conjugates using liquid chromatography/tandem mass spectrometry. *Rapid Communications in Mass Spectrometry*. 2008;22(7):1032-1040

- [82] Dieckhaus CM, Fernandez-Metzler CL, King R, Krolkowski PH, Baillie TA. Negative ion tandem mass spectrometry for the detection of glutathione conjugates. *Chemical Research in Toxicology*. 2005;**18**(4):630-638
- [83] Lin JH, Lu AY. Role of pharmacokinetics and metabolism in drug discovery and development. *Pharmacological Reviews*. 1997;**49**(4):403-449
- [84] Alavijeh MS, Palmer AM. The pivotal role of drug metabolism and pharmacokinetics in the discovery and development of new medicines. *IDrugs*. 2004;**7**(8):755-763
- [85] Ackermann BL, Berna MJ, Murphy AT. Recent advances in use of LC/MS/MS for quantitative high-throughput bioanalytical support of drug discovery. *Current Topics in Medicinal Chemistry*. 2002;**2**:53-66
- [86] Hopfgartner G, Bourgoigne E. Quantitative high-throughput analysis of drugs in biological matrices by mass spectrometry. *Mass Spectrometry Reviews*. 2003;**22**(3):195-214
- [87] Cox KA, White RE, Korfmacher WA. Rapid determination of pharmacokinetic properties of new chemical entities: in vivo approaches. *Combinatorial Chemistry & High Throughput Screening*. 2002;**5**(1):29-37
- [88] Ong VS, Cooke KL, Kosara CM, Brubaker WF. Quantitative bioanalysis: An integrated approach for drug discovery and development. *International Journal of Mass Spectrometry*. 2004;**238**:139-152
- [89] Manitpisitkul P, White RE. Whatever happened to cassette-dosing pharmacokinetics? *Drug Discovery Today*. 2004;**9**(15):652-658
- [90] Ohkawa T, Ishida Y, Kanaoka E, Takahashi K, Okabe H. A new generic column switching system for quantitation in cassette dosing using LC/MS/MS. *Journal of Pharmaceutical and Biomedical Analysis*. 2003;**31**:1089-1099
- [91] Zhang MY, Kerns E, McConnell O, Sonnenberg-Reines J, Zaleska MM. Brain and plasma exposure profiling in early drug discovery using cassette administration and fast liquid chromatography-tandem mass spectrometry. *Journal of Pharmaceutical and Biomedical Analysis*. 2004;**34**:359-368
- [92] Sadagopan N, Pabst B, Cohen L. Evaluation of online extraction/mass spectrometry for in vivo cassette analysis. *Journal of Chromatography. B, Analytical Technologies in the Biomedical and Life Sciences*. 2005;**820**(1):59-67
- [93] White RE, Manitpisitkul P. Pharmacokinetic theory of cassette dosing in drug discovery screening. *Drug Metabolism and Disposition*. 2001;**29**(7):957-966
- [94] Hsieh Y, Wang G, Wang Y, Chackalamannil S, Brisson JM. Simultaneous determination of a drug candidate and its metabolite in rat plasma samples using ultrafast monolithic column high-performance liquid chromatography/tandem mass spectrometry. *Rapid Communications in Mass Spectrometry*. 2002;**16**:944-950
- [95] Jemal M, Ouyang Z. Enhanced resolution triple-quadrupole mass spectrometry for fast quantitative bioanalysis using liquid chromatography/tandem mass spectrometry: Investigations of parameters that affect ruggedness. *Rapid Communications in Mass Spectrometry*. 2003;**17**:24-38

- [96] Romanyshyn L, Tiller PR, Alvaro R, Pereira A, Hop CE. Ultra-fast gradient vs fast isocratic chromatography in bioanalytical quantification by liquid chromatography/tandem mass spectrometry. *Rapid Communications in Mass Spectrometry*. 2001;15:31-319
- [97] Hsieh Y, Chintala M, Mei H, Agans J, Brisson JM. Quantitative screening and matrix effect studies of drug discovery compounds in monkey plasma using fast-gradient liquid chromatography/tandem mass spectrometry. *Rapid Communications in Mass Spectrometry*. 2001;15:2481-2487
- [98] Dunn-Meynell KW, Wainhaus S, Korfmacher WA. Optimizing an ultrafast generic high-performance liquid chromatography/tandem mass spectrometry method for faster discovery pharmacokinetic sample throughput. *Rapid Communications in Mass Spectrometry*. 2005;19:2905-2910
- [99] Tanak N, Kobayashi H, Ishizuka N, Minakuchi H, Nakanishi K, Hosoya K, et al. Monolithic silica columns for high-efficiency chromatographic separations. *Journal of Chromatography. A*. 2002;965(1-2):35-49
- [100] Tanaka N, Kobayashi H, Nakanishi K, Minakuchi H, Ishizuka N. Monolithic LC columns. *Analytical Chemistry*. 2001;73(15):420A-429A
- [101] Rozenbrand J, van Bennekom WP, Unger KK, de Jong GJ. Fast LC separation of a myoglobin digest: A case study using monolithic and particulate RP 18 silica capillary columns. *Analytical and Bioanalytical Chemistry*. 2006;385(6):1055-1061
- [102] Korfmacher WA, Veals J, Dunn-Meynell K, Zhang X, Tucker G. Demonstration of the capabilities of a parallel high performance liquid chromatography tandem mass spectrometry system for use in the analysis of drug discovery plasma samples. *Rapid Communications in Mass Spectrometry*. 1999;13:1991-1998
- [103] Jemal M, Huang M, Mao Y, Whigan D, Powell ML. Increased throughput in quantitative bioanalysis using parallel-column liquid chromatography with mass spectrometric detection. *Rapid Communications in Mass Spectrometry*. 2001;15:994-999
- [104] Wu JT. The development of a staggered parallel separation liquid chromatography/tandem mass spectrometry system with on-line extraction for high-throughput screening of drug candidates in biological fluids. *Rapid Communications in Mass Spectrometry*. 2001;15:73-81
- [105] Taylor PJ. Matrix effects: The Achilles heel of quantitative high-performance liquid chromatography-electrospray-tandem mass spectrometry. *Clinical Biochemistry*. 2005;38(4):328-334
- [106] Hall TG, Smukste I, Bresciano KR, Wang Y, McKearn D, Savage RE. Identifying and overcoming matrix effects in drug discovery and development. In: *Tandem Mass Spectrometry-kApplications and Principles*. Rijeka: InTech; 2012
- [107] Bakhtiar R, Majumdar TK. Tracking problems and possible solutions in the quantitative determination of small molecule drugs and metabolites in biological fluids using liquid chromatography-mass spectrometry. *Journal of Pharmacological and Toxicological Methods*. 2007;55(3):227-243
- [108] Côté C, Bergeron A, Mess J-N, Furtado M, Garofolo F. Matrix effect elimination during LC-MS/MS bioanalytical method development. *Bioanalysis*. 2009;1(7):1243-1257

- [109] Trufelli H, Palma P, Famigliani G, Cappiello A. An overview of matrix effects in liquid chromatography–mass spectrometry. *Mass Spectrometry Reviews*. 2011;**30**(3):491-509
- [110] Vijaya BV. Identification and reduction of matrix effects caused by polyethylene glycol 400 in bioanalysis using liquid chromatography/tandem mass spectrometry. *International Journal of Pharmaceutical Innovations*. 2013;**3**(1):48-65
- [111] Vijaya Bhaskar V, Middha A, Tiwari S, Shivakumar S. Identification and reduction of matrix effects caused by cremophor EL in bioanalysis using liquid chromatography/tandem mass spectrometry. *Journal of Analytical and Bioanalytical Techniques*. 2013;**4**(3):1-7
- [112] Vijaya Bhaskar V, Sudhir T, Anil M, Savithiri S. Identification and reduction of matrix effects caused by Solutol Hs15 in bioanalysis using liquid chromatography/tandem mass spectrometry. *Journal of Analytical and Bioanalytical Techniques*. 2013;**4**(166):1-8
- [113] Tong XS, Wang J, Zheng S, Pivnichny JV, Griffin PR, Shen X, et al. Effect of signal interference from dosing excipients on pharmacokinetic screening of drug candidates by liquid chromatography/mass spectrometry. *Analytical Chemistry*. 2002;**74**(24):6305-6313
- [114] Shou WZ, Naidong W. Post-column infusion study of the ‘dosing vehicle effect’ in the liquid chromatography/ tandem mass spectrometric analysis of discovery pharmacokinetic samples. *Rapid Communications in Mass Spectrometry*. 2003;**17**(6):589-597
- [115] Tiller PR, Romanyshyn LA. Implications of matrix effects in ultra-fast gradient or fast isocratic liquid chromatography with mass spectrometry in drug discovery. *Rapid Communications in Mass Spectrometry*. 2002;**16**(2):92-98
- [116] Vijaya Bhaskar V, Anil M. Liquid chromatography/tandem mass spectrometry method for quantitation of Cremophor EL and its applications. *International Journal of Analytical Chemistry*. 2013;**2013**:1-11
- [117] Vijaya Bhaskar V, Middha A, Tiwari S, Shivakumar S. Liquid chromatography/tandem mass spectrometry method for quantitative estimation of polyethylene glycol 400 and its applications. *Journal of Chromatography B*. 2013;**926**:68-76
- [118] Vijaya Bhaskar V, Middha A, Tiwari S, Shivkumar S. Determination of Cremophor EL in rat plasma by LC-MS/ MS: Application to a pharmacokinetic study. *Journal of Analytical and Bioanalytical Techniques*. 2013;**4**:163
- [119] Vijaya Bhaskar V, Middha A, Srivastava P, Rajagopal S. Liquid chromatography/tandem mass spectrometry method for quantitative estimation of solutol HS15 and its applications. *Journal of Pharmaceutical Analysis*. 2015;**5**(2):120-129
- [120] Cech NB, Enke CG. Practical implications of some recent studies in electrospray ionization fundamentals. *Mass Spectrometry Reviews*. 2001;**20**(6):362-387
- [121] King R, Bonfiglio R, Fernandez-Metzler C, Miller-Stein C, Olah T. Mechanistic investigation of ionization suppression in electrospray ionization. *Journal of the American Society for Mass Spectrometry*. 2000;**11**(11):942-950
- [122] Bennett P, Liang H, editors. *Overcoming Matrix Effects Resulting from Biological Phospholipids through Selective Extractions in Quantitative LC/MS/MS*. 52nd ASMS Conference

on Mass Spectrometry. Nashville, Tennessee; 2004

mass spectrometry. Journal of Chromatography. A. 2004;**1042**(1-2):113-121

[123] Chambers E, Wagrowski-Diehl DM, Lu Z, Mazzeo JR. Systematic and comprehensive strategy for reducing matrix effects in LC/MS/MS analyses. Journal of Chromatography B. 2007;**852**(1-2):22-34

[124] Bonfiglio R, King RC, Olah TV, Merkle K. The effects of sample preparation methods on the variability of the electrospray ionization response for model drug compounds. Rapid Communications in Mass Spectrometry. 1999;**13**(12):1175-1185

[125] Van Hout M, Niederländer H, De Zeeuw R, De Jong G. Ion suppression in the determination of clenbuterol in urine by solid-phase extraction atmospheric pressure chemical ionisation ion-trap mass spectrometry. Rapid Communications in Mass Spectrometry. 2003;**17**(3):245-250

[126] Schuhmacher J, Zimmer D, Tesche F, Pickard V. Matrix effects during analysis of plasma samples by electrospray and atmospheric pressure chemical ionization mass spectrometry: Practical approaches to their elimination. Rapid Communications in Mass Spectrometry. 2003;**17**(17):1950-1957

[127] Larger PJ, Breda M, Fraier D, Hughes H, James CA. Ion-suppression effects in liquid chromatography-tandem mass spectrometry due to a formulation agent, a case study in drug discovery bioanalysis. Journal of Pharmaceutical and Biomedical Analysis. 2005;**39**(1-2):206-216

[128] Renew JE, Huang C-H. Simultaneous determination of fluoroquinolone, sulfonamide, and trimethoprim antibiotics in wastewater using tandem solid phase extraction and liquid chromatography-electrospray